

# P4 Pellet

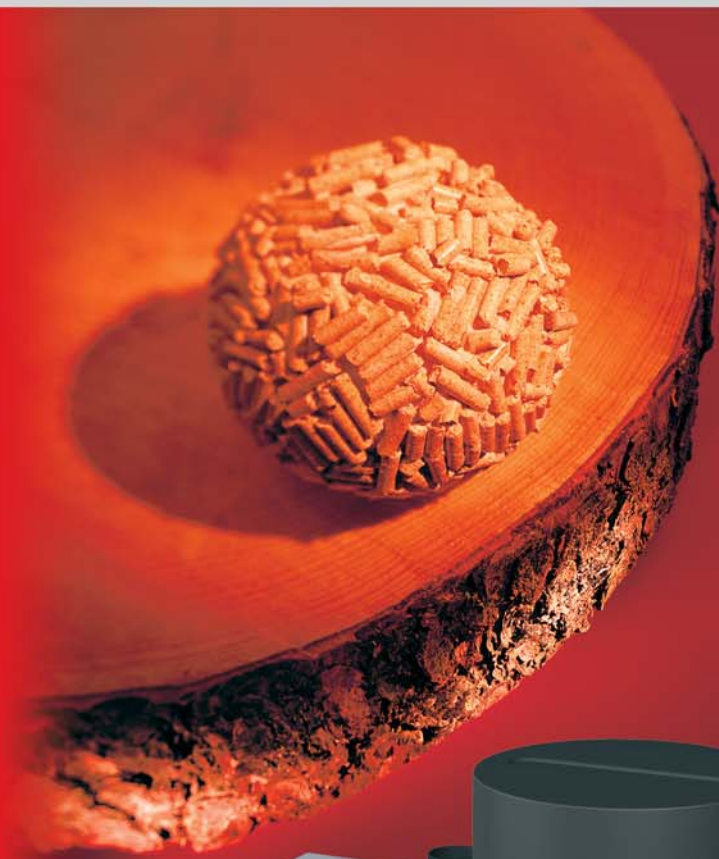

# Heating with pellets

## From a renowned company

Right from the start, Fröling has specialised in the efficient use of wood as an energy source. Today the Fröling name stands for modern biomass heating technology. Our firewood, waste wood and pellet boilers are used successfully across Europe. All products are produced at our own factories in Austria and Germany.

The state of the art machinery guarantees quality down to the smallest detail. Fröling's dense service network ensures customers' needs are handled quickly and reliably.



## What are pellets

Wood pellets are made from natural wood. The wood shavings and sawdust produced in large quantities as a by-product in the wood processing industry are compacted and pelleted untreated. Pellets have a high energy density and are easy to deliver and store. These are just some of the advantages that make pellets the perfect fuel for fully-automatic heating systems.



Pellet are delivered by tanker which unloads the pellets directly into the your wood store. When you buy pellets you should pay particular attention to the quality offered. Only manufacturers tested to meet norms can guarantee quality.

## The next generation of pellet boilers

Fröling has set new international standards for technology and design with the new P4 Pellet. With its ingenious fully automatic operation, this new product from Fröling is amazingly easy to use. Our engineers' years of experience have influenced the P4 Pellet. However it is not just the advanced technology that points to a trend of the future. A high importance was placed on design.



# The latest technology

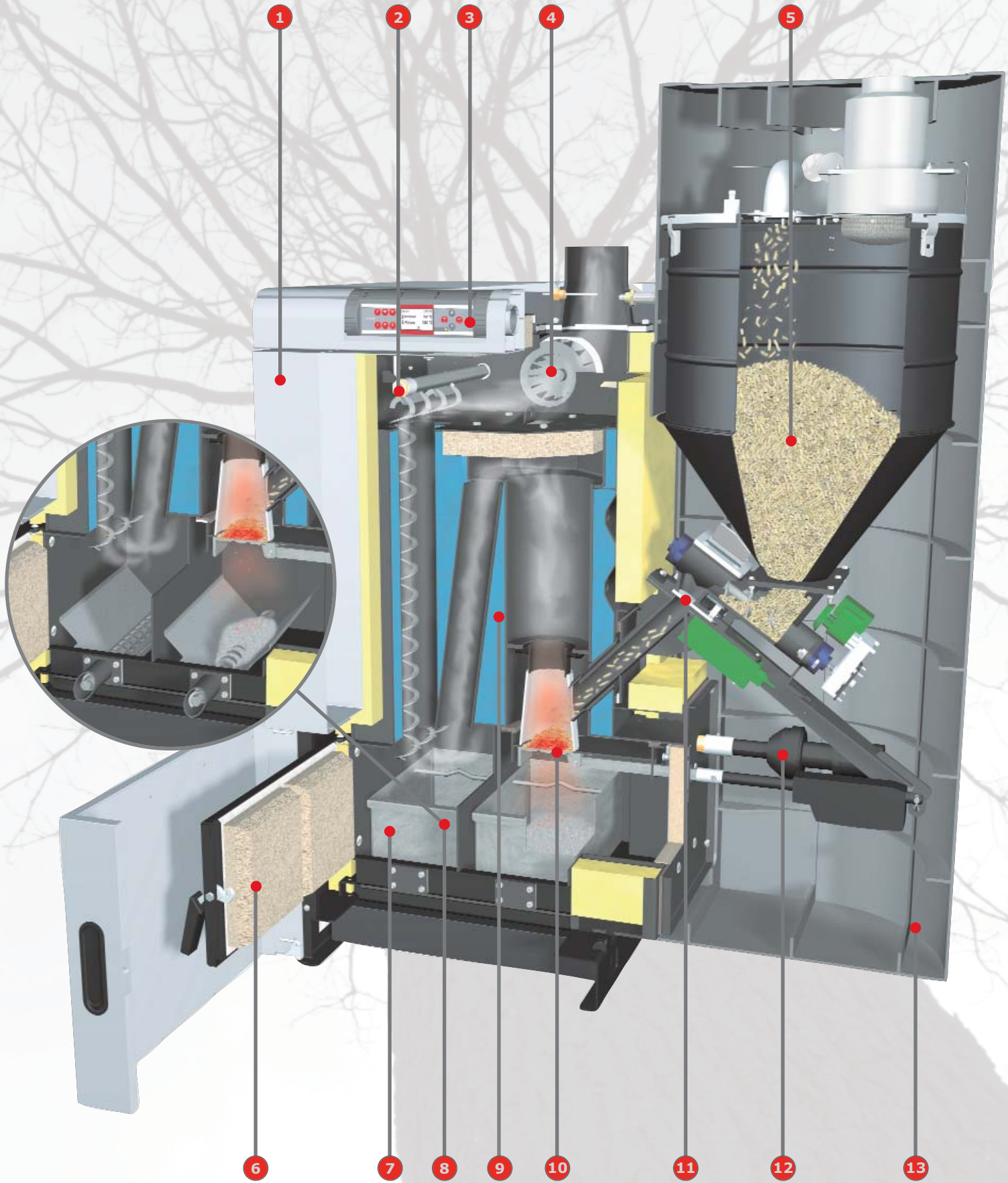



## The pellet boiler with special benefits:

- 1 Insulation combined with a unique design for heat retention.
- 2 EOS technology (Efficiency Optimisation System) for high efficiency with automatic drive for continuous cleaning.
- 3 Innovative bus control concept with Lambdatronic P3200 microprocessor control.
- 4 Speed regulated induced draught fan for the highest operating safety.
- 5 Spacious store container with automatic pellet feed.
- 6 Insulated cleaning door for excellent heat retention.
- 7 Practical ash container for easy emptying of ash.  
The ample dimensions make it possible to leave a longer emptying interval.
- 8 The optional ash removal screws transport the ash to two closed ash boxes for even easier ash emptying.
- 9 Patented multiple-pass heat exchanger for variable boiler operation. The P4 Pellet is also ideally suited for heating for energy saving houses. You benefit from the 3-pass design of the heat exchanger, which guarantees the highest possible ash separation. This also means that an external return feed increase is not necessary.
- 10 Automatic sliding grate for ash removal, offering almost maintenance-free operation.
- 11 Tested sealed slider guarantees safe operation of the boiler.
- 12 Automatic ignition
- 13 Special cyclone fitment with integrated silencer for quiet operation.

# Perfection in the details

## Feature: Plug and Play

- Benefits:
- Unpack, plug it in, start heating
  - Compact
  - Easy positioning

The P4 Pellet has important advantages even before it is put into the boiler room. As it is so compact, it is child's play to place the P4 in even a confined boiler room. All components are already fully wired. They are "Plug and Play" and shortly after the boiler has been put in position you can start the heating process. If necessary, the most important components can be removed in just a few steps for easier positioning. This saves time and money.



## Feature: Extensive safety concepts

- Benefits:
- The highest possible operating safety
  - Maximum reliability

The drop tube, together with the tried and tested safety sealed slider and the suction locking, provides a lock system for the highest operating safety. The self test before the system starts and the automatic diagnostics system guarantee safe operation.





**Feature: Speed regulated induced draught fan and lambda control**

- Benefits:
- Maximum ease of use
  - Permanent optimisation of combustion

The serially controlled, speed regulated induced draught fan ensures the exact air quantity for combustion. Working together with the serially controlled lambda control, it ensures optimum combustion conditions.

**Feature: Variable operation**

- Benefits:
- Maximum boiler efficiency
  - Considerable cost savings
  - Long lifespan

The patented multiple-pass heat exchanger means the P4 Pellet can adapt operation optimally in every respect. An external return feed increase is not necessary. This means considerable cost savings. Because of the special boiler construction, the P4 Pellet is sure of a long lifetime.

**Feature: Self-cleaning system**

- Benefits:
- Clean combustion
  - Very low emissions
  - Automatic ash removal

With the P4 Pellet you are choosing a quality product. The automatic sliding grate enables almost maintenance free operation. The innovative 3-pass design means very long combustion, ensuring very low emissions and protecting the environment. The P4 Pellet boiler is amazingly easy to use. Ash is always generated when wood or pellets are burnt. With the P4 it is transported automatically to two ash containers, which can be emptied simply and easily.



# Systematic comfort

## Feature: **Lambdatronic P 3100 control system**

- Benefits:
- Exact combustion control through its serially controlled lambda control
  - Large, clear control unit with adjustable viewing angle
  - Menu-based operation with online help
  - Boiler navigation from the living room



With the new H 3200 boiler control, Fröling is taking a step into the future. The control unit, optimised to fit requirements, and the individually adjustable viewing angle guarantees that all operating statuses are clearly shown. The optimally organised menu structure makes it easy to operate. The important heating and hot water functions can be selected simply using the function keys.

The innovative **Fröling bus system** makes it possible to install extension modules in any location. For example, at the boiler, at the heat distributor, at the tank, in the living room or in the next house: the local controls can be installed wherever they are needed. The minimum of electrical cables is another plus.

You can have even more comfort with the new **RBG 3200 room console**. The heating system is controlled easily from your living room. It is extremely easy to read off all the important values and status messages and to change settings at the push of a button.



**Feature:** **Systems engineering for optimum energy consumption**

- Benefits:
- Complete solution for all requirements
  - The components work together perfectly
  - Links in to solar energy

Fröling systems engineering enables efficient energy management. Up to 4 storage tanks, up to 8 hot water tanks and up to 18 heating circuits can influence the heat management. You also benefit from the option of connecting other types of energy generation, such as solar panel systems.

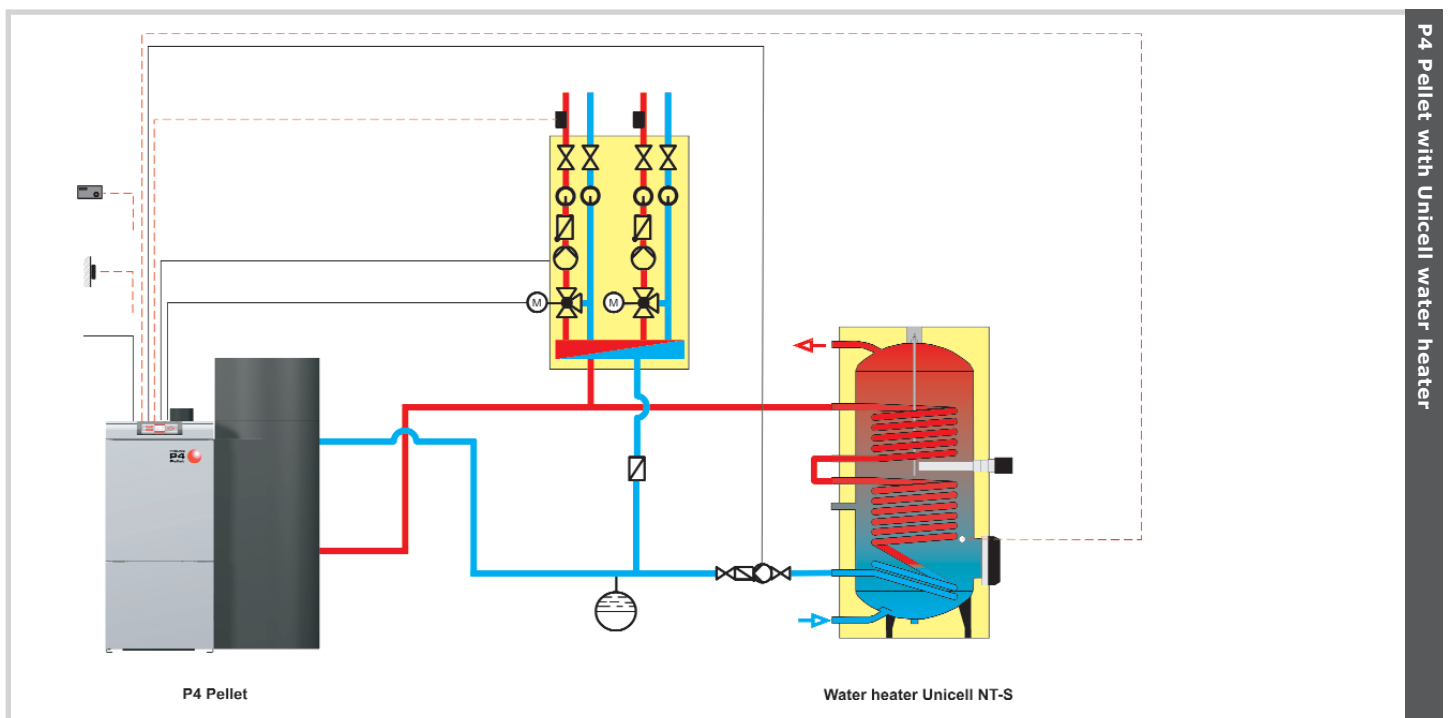
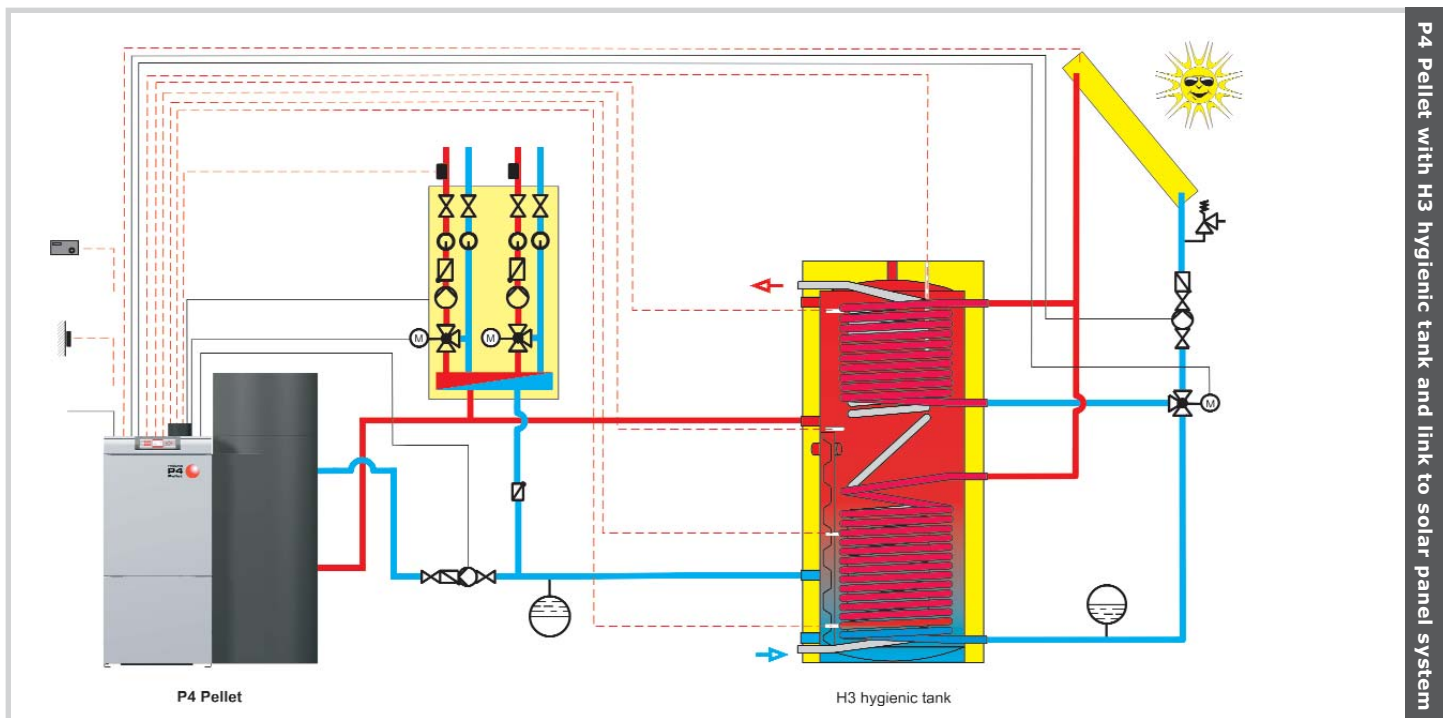

# Systematic feed

## Universal suction system

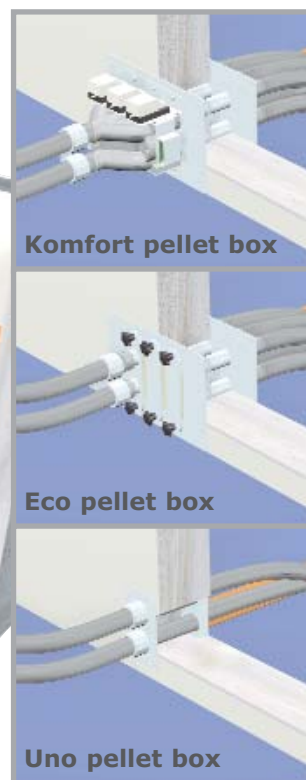
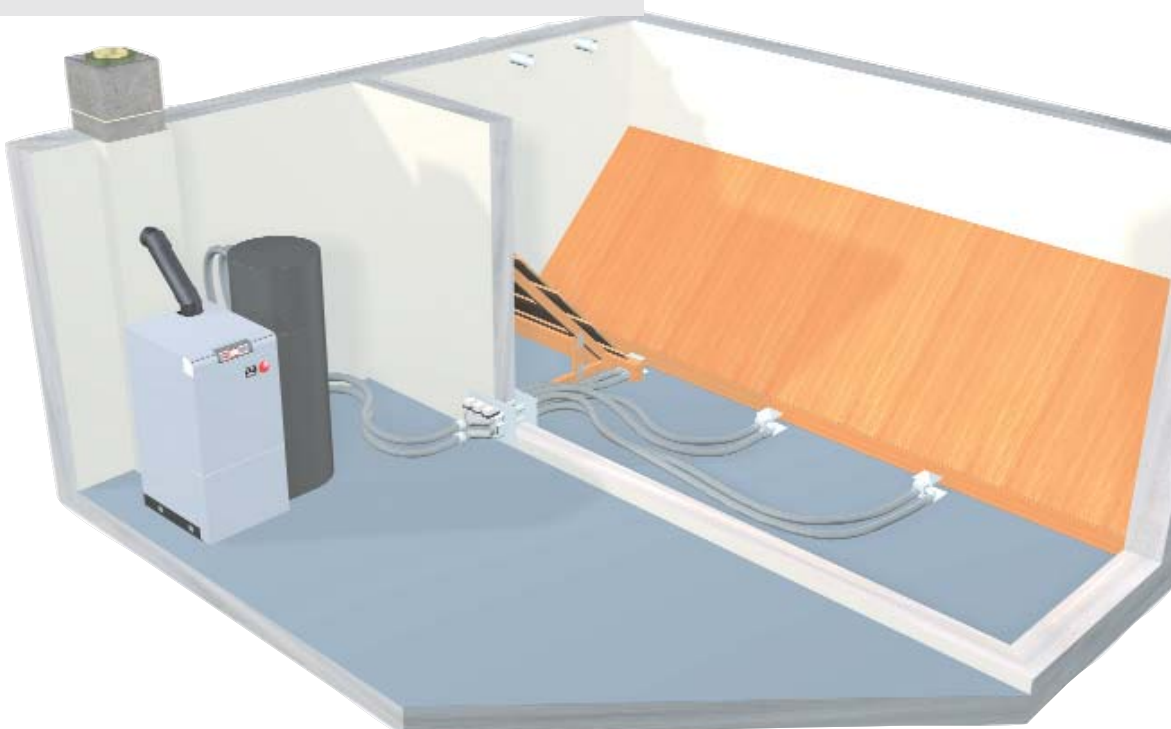

The universal suction system is designed for those situations where the store is not next to the boiler room and the pellets have to be fed over a considerable distance. The position of the suction probes or the pellet box can be adjusted to fit the conditions of the store optimally. The system is easy to install and very flexible.

## Bag silo system

The bag silo system is a flexible, simple way of storing pellets.

There are other advantages to using a bag silo. It is easy to assemble and store. It is dustproof and flood proof. You can fit rainproof and sun proof covers and install the silo outside.

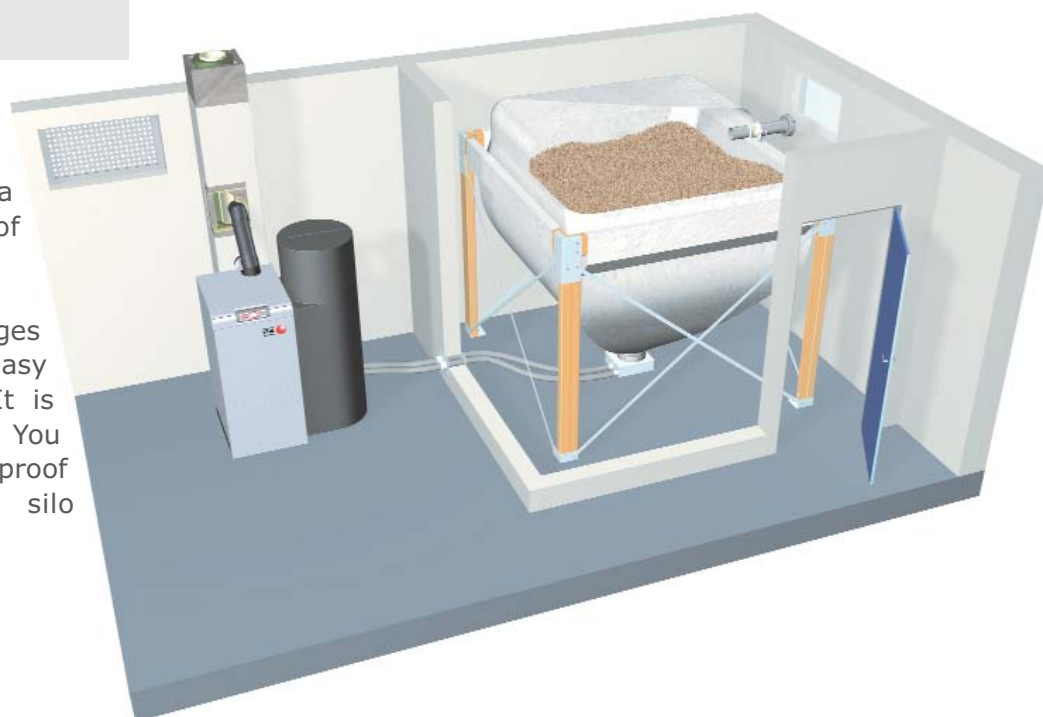

## Screw suction system

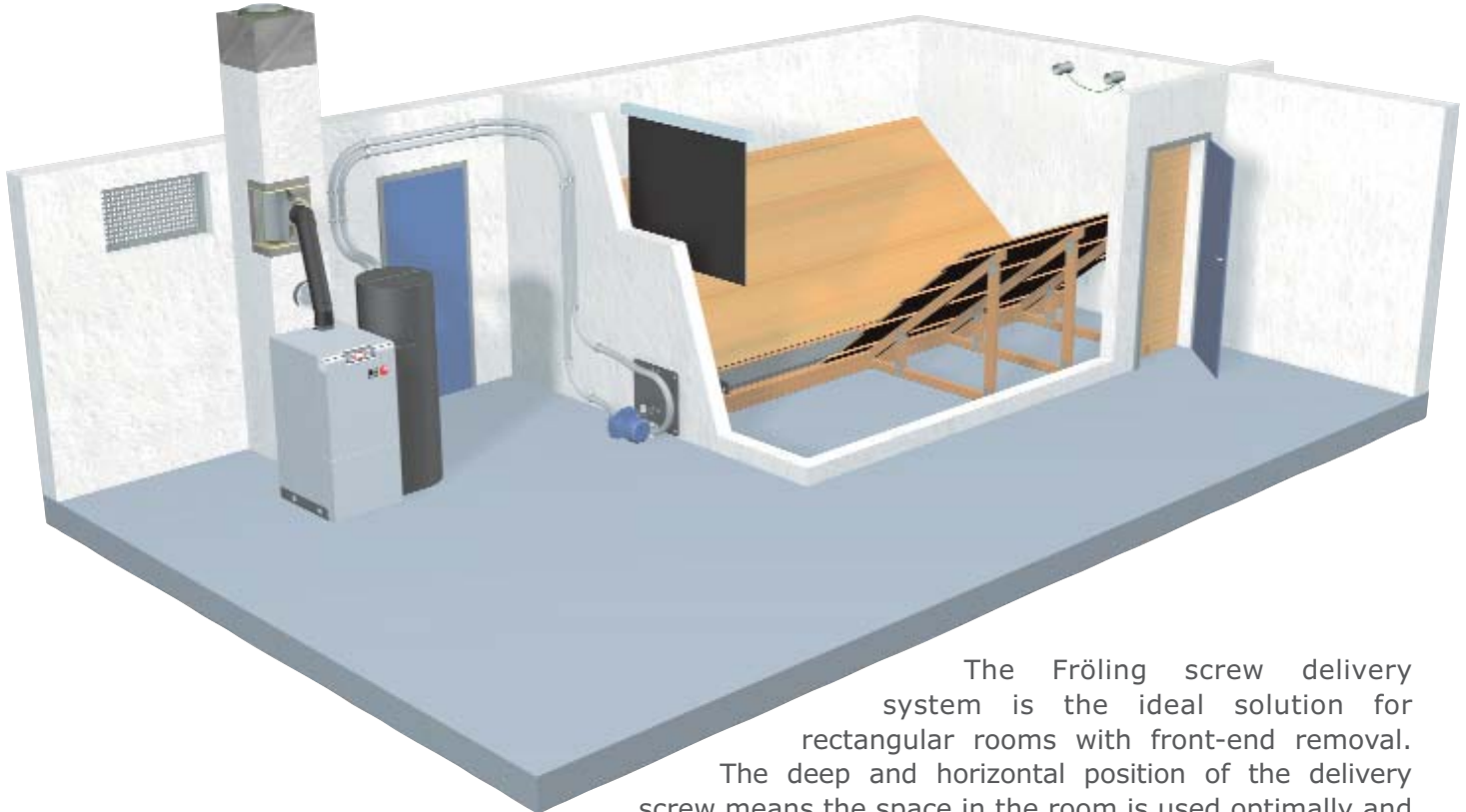

The Fröling screw delivery system is the ideal solution for rectangular rooms with front-end removal. The deep and horizontal position of the delivery screw means the space in the room is used optimally and complete emptying of the store is guaranteed. Combined with a suction system from Fröling it also enables flexible boiler setup.

## Underground feeder tank system

If you have no storage space indoors then the underground tank is a good alternative. The underground tank is buried outdoors and feeds pellets to the boiler via a suction pipe. The suction pipes should be laid inside a hollow pipe from the underground tank to the building.

Filling takes place through a shaft installed above the pellet tank.

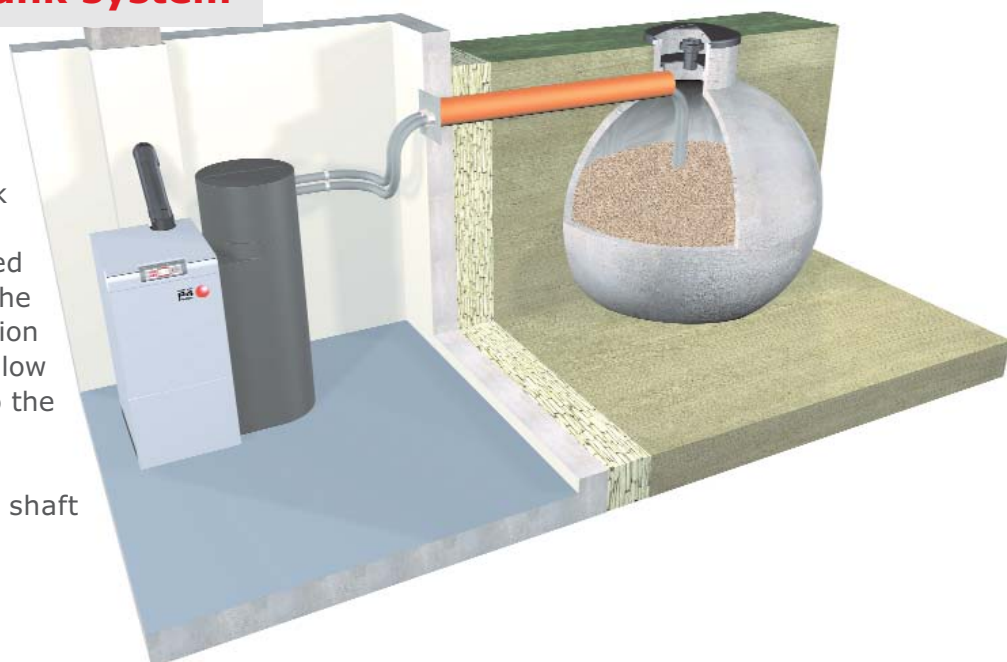

# Technical specifications

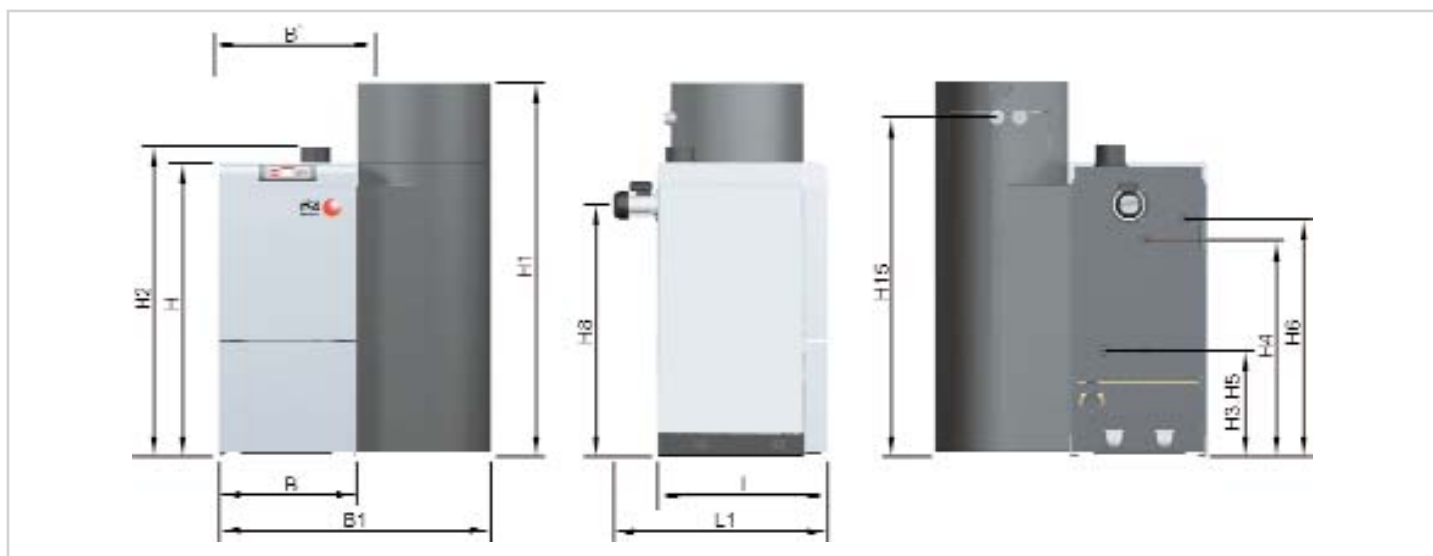

Dimensions - P4 Pellet			P4 8	P4 15	P4 20	P4 25	P4 32	P4 38
L	Length, boiler <sup>1)</sup>	[mm]	740	740	740	740	740	740
L1	Total length inc. induced draught fan	[mm]	930	930	930	930	930	930
B	Width, boiler	[mm]	600	600	770	770	830	830
B*	Width, boiler inc. support <sup>2)</sup>	[mm]	700	700	870	870	930	930
B1	Total width, inc. suction cyclone	[mm]	1185	1185	1355	1355	1415	1415
H	Height, boiler <sup>3)</sup>	[mm]	1280	1280	1280	1280	1430	1430
H1	Total height, inc. suction cyclone	[mm]	1660	1660	1660	1660	1900	1900
H2	Height, flue gas pipe connection	[mm]	1350	1350	1350	1350	1530	1530
H3	Height, outfeed connection	[mm]	460	460	460	460	460	460
H4	Height, return feed connection	[mm]	940	940	955	955	1070	1070
H5	Height, drainage connection	[mm]	460	460	460	460	460	460
H6	Height, ventilation connection	[mm]	1030	1030	1030	1030	1160	1160
H8	Height, induced draught fan connection	[mm]	1095	1095	1095	1095	1215	1215
H15	Height, suction system connection	[mm]	1480	1480	1480	1480	1720	1720
	Flue pipe diameter	[mm]	130	130	130	130	150	150

1) Corresponds to the minimum positioning length

2) Width of the boiler inc. support for positioning unit. Corresponds to the minimum positioning length after removing the stoker fitment, suction cyclone and positioning unit.

3) Corresponds to the minimum positioning height after removing the stoker fitment, suction cyclone and positioning unit.

Technical specifications - P4 Pellet			P4 8	P4 15	P4 20	P4 25	P4 32	P4 38
Rated heat output	[kW]		10,5	14,9	20,0	25,0	32,0	38,0
Heat output range	[kW]		3,1 - 10,5	3,1 - 14,9	6,0 - 20,0	7,5 - 25,0	8,9 - 32,0	8,9 - 38,0
Power output	W		96	96	130	130	130	130
Water capacity	L		70	70	80	80	125	125
Weight of the boiler <sup>4)</sup>	[kg]		320	320	400	400	470	470

4) Specified weight refers to the boiler without ash removal module

You can find more technical information and tips about Heating with pellets from our detailed planning documentation.

P0190007 - All illustrations intended as a guide only.  
We reserve the right to make technical changes without prior notice.  
Errors and omissions excepted.  
Sources for external image material: [www.aboutpixel.de](http://www.aboutpixel.de), [www.pixelio.de](http://www.pixelio.de)

**froling** 

**Heizkessel- und Behälterbau GesmbH  
A-4710 Grieskirchen, Industriestr. 12**

Tel ++43 (0) 7248 606 • Fax ++43 (0) 7248 606-600  
E-mail: [info@froeling.com](mailto:info@froeling.com) • Internet: [www.froeling.com](http://www.froeling.com)